

# ARCHICOUTURE

issue number 01 / February 2022

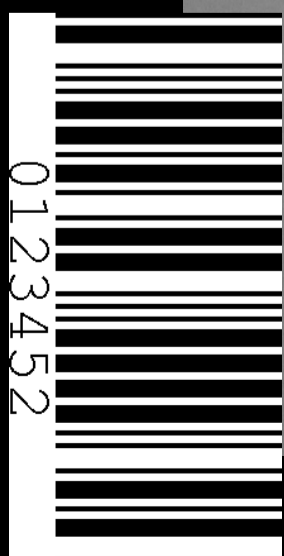

SPECIAL LIMITED EDITION ||



ARCHICOUTURE

---

WELCOME  
TO A PLACE  
WHERE  
ARCHITECTURE  
MEETS  
FASHION  
DESIGN...

ARCHICOUTURE

Self-portrait,  
2013 Photography Karl  
Lagerfeld







Iris Van Herpen  
Photos: Filippo Fior  
Paris Fashion Week 2019





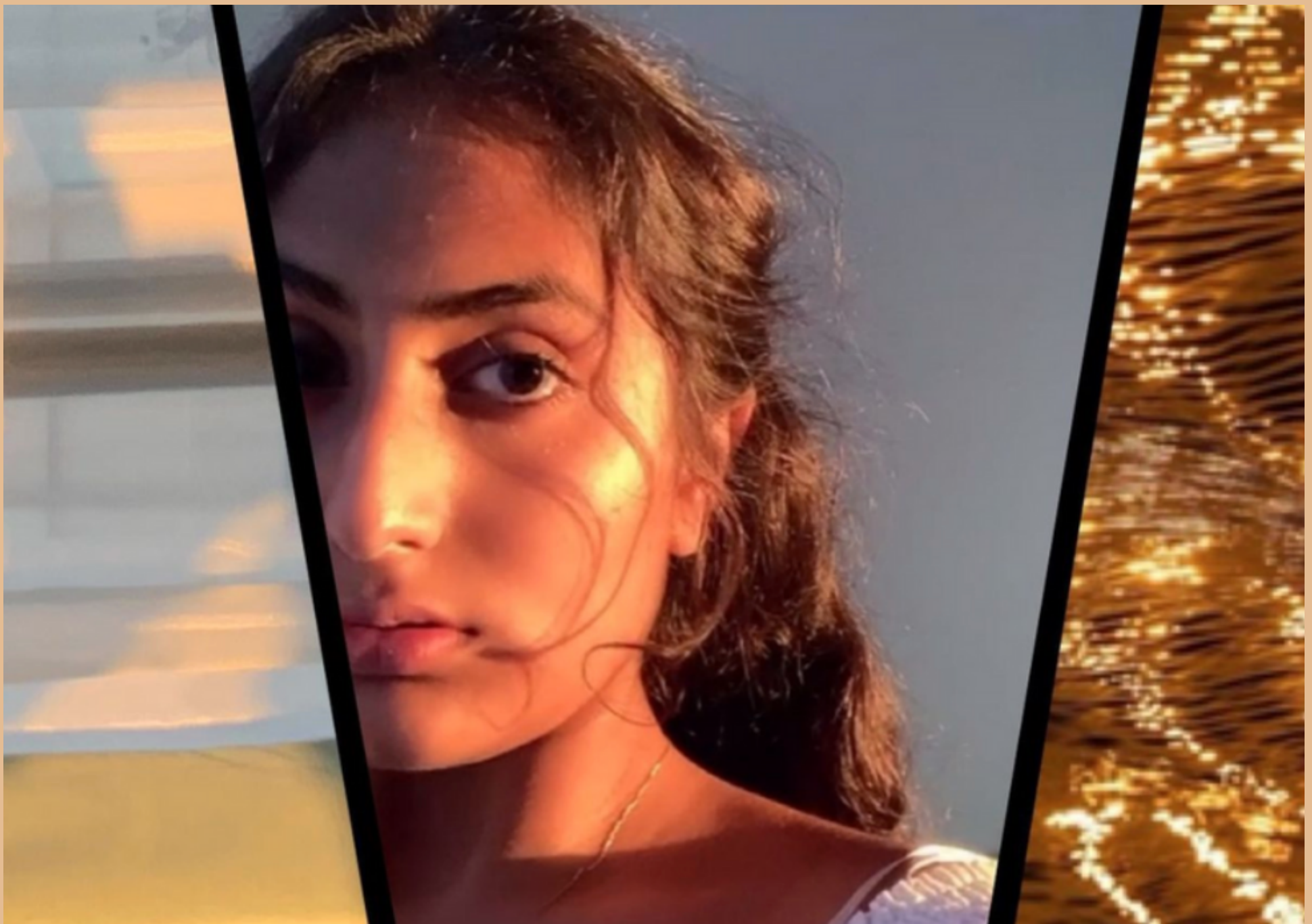

# The Last Of The Independents

A story beginning with the construction of modern fashion culture. Fashion is a form of art, expressed through design, and color. Unknown to many, architecture and the fashion industry fall hand in hand, creating structures that display meaning and emotion based on functionality and one based on trend. Introducing these two industries together brings new ideas and creative processes into the mix.

As the editor and chief of Archicouture, I display my own designs and personal creations and open a window for small businesses and unknown artists to be recognized. As a fashion designer and young entrepreneur, the struggle of being shown to the world is more than great.

I hope and wish to see the combination between the two industries spring to life in its own place within the world. As the thought and process of creating this magazine had split me into an ultimatum between architecture and fashion design, opening my eyes to look between the cracks sprung the idea of Archicouture. May you enjoy this read and let your creative mind get to work on what your heart desires.

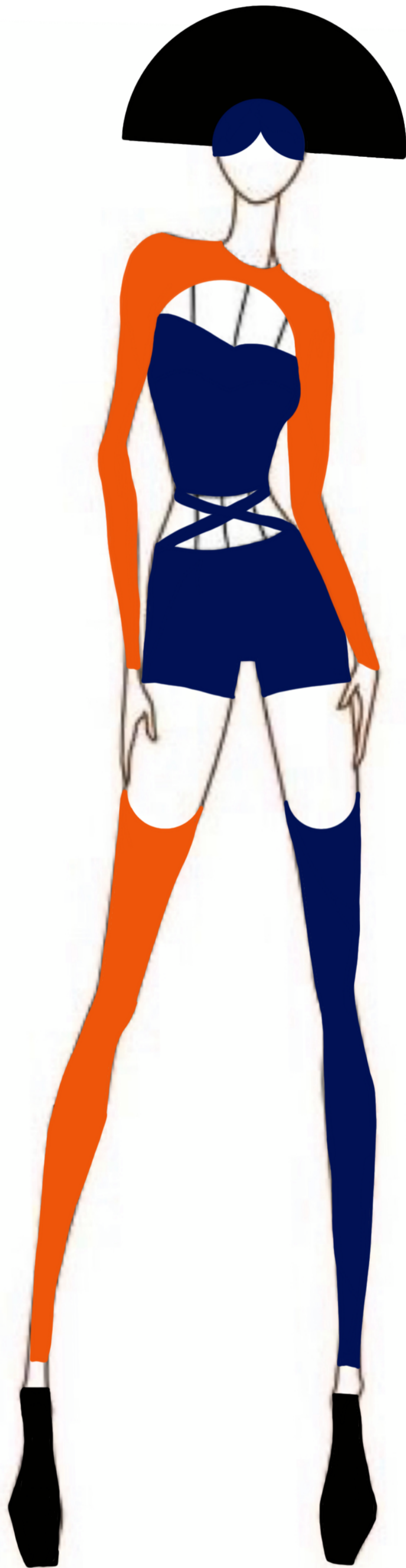

# The blue

## fit

**T**he blue fit is a tight short and top combination that Badria Kazim designed to mix contrasting colors. The orange outline used to cover the arms really draws attention to this piece. By adding in the base of the canvas to be dark blue the eyes directly focus on the vibrant orange and then travel to the darker shade of blue.

The cross section located at the waist would bring the illusion of a tight slim fit waist whilst also showing off the casualness in this outfit. "Fit" being the word to describe this piece features shoes and a headpiece alongside the suit itself.

Protractor looking headpiece really brings back the Cleopatra elegance of this outfit. The cuffing on the wings covering the forehead of the model allow stability but also take the headpiece from a headband to more of a crown.

Badria Kazim's focus on 2 tones in her fashion designs is a recurring figure.

By leaving the upper chest to collar bone area open, it allows for the skin color of the person to wear this design to seep through. Badria Kazim says, "Skin color is something that has been looked at in such a negative manor thanks to systemic racism and stereotypes, by using the authentic hue of each individual this piece brings in that color and provides balance for the fit. "

Wise words, bringing in world issues and expressing beautiful of humankind into fashion is something not seen done before in the fashion industry but is sure to be looked up to by many.

Overall this take on casual and fancy out-wear has really spoken out on how fashion will change in the future.





# ~ future

Archicouture has featured this fashion piece created by Badria Kazim to showcase what the future of fashion and couture will bring to the table to match the extravagance of this piece



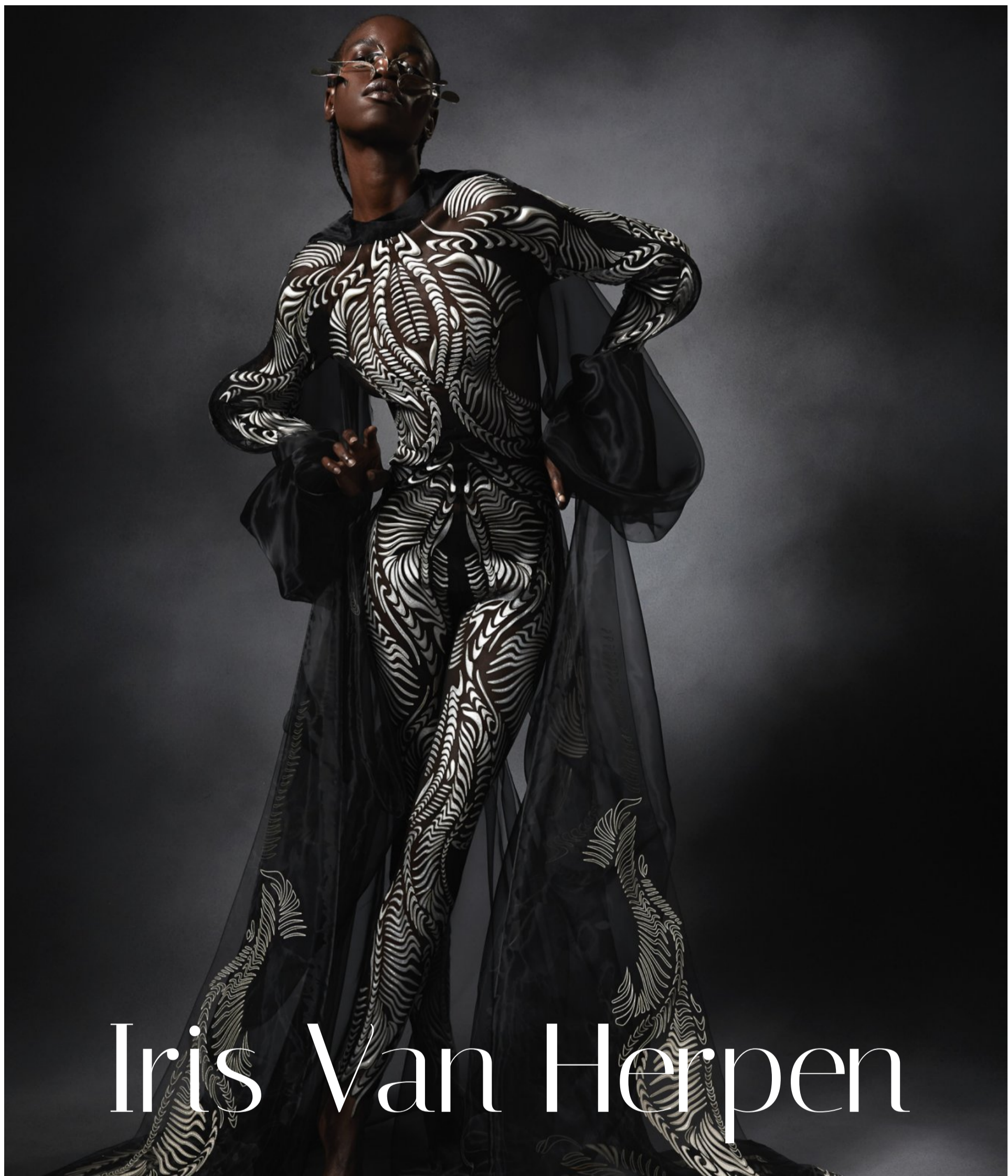

# Iris Van Herpen

Iris Van Herpen is a Dutch fashion designer who is famously known for her cutting-edge technology used in her incredible organic clothing. Iris Van Herpen's most recent collection is named, "Earthrise", this was first showcased in 2021 Paris fashion week for the upcoming fall collection. The collection includes 18 new pieces all different and unique to her previous collection. Her designs use color and structure to create extraordinary art pieces. She crosses the boundaries between technology, art, and fashion.

In a statement on the brand's website, an employee says that "Van Herpen is always questioning what couture can be, including by suggesting that 3D printing can be as unique as a hand-sewn garment. She's formed an alliance with science, and she regularly works with people outside of the fashion industry to bring new perspectives to it."

Many of the pieces included in Earthrise are created using laser-cut fabric pieces and 3D printing to form flowing and structured dresses, emphasizing the designers interest in the female figure.

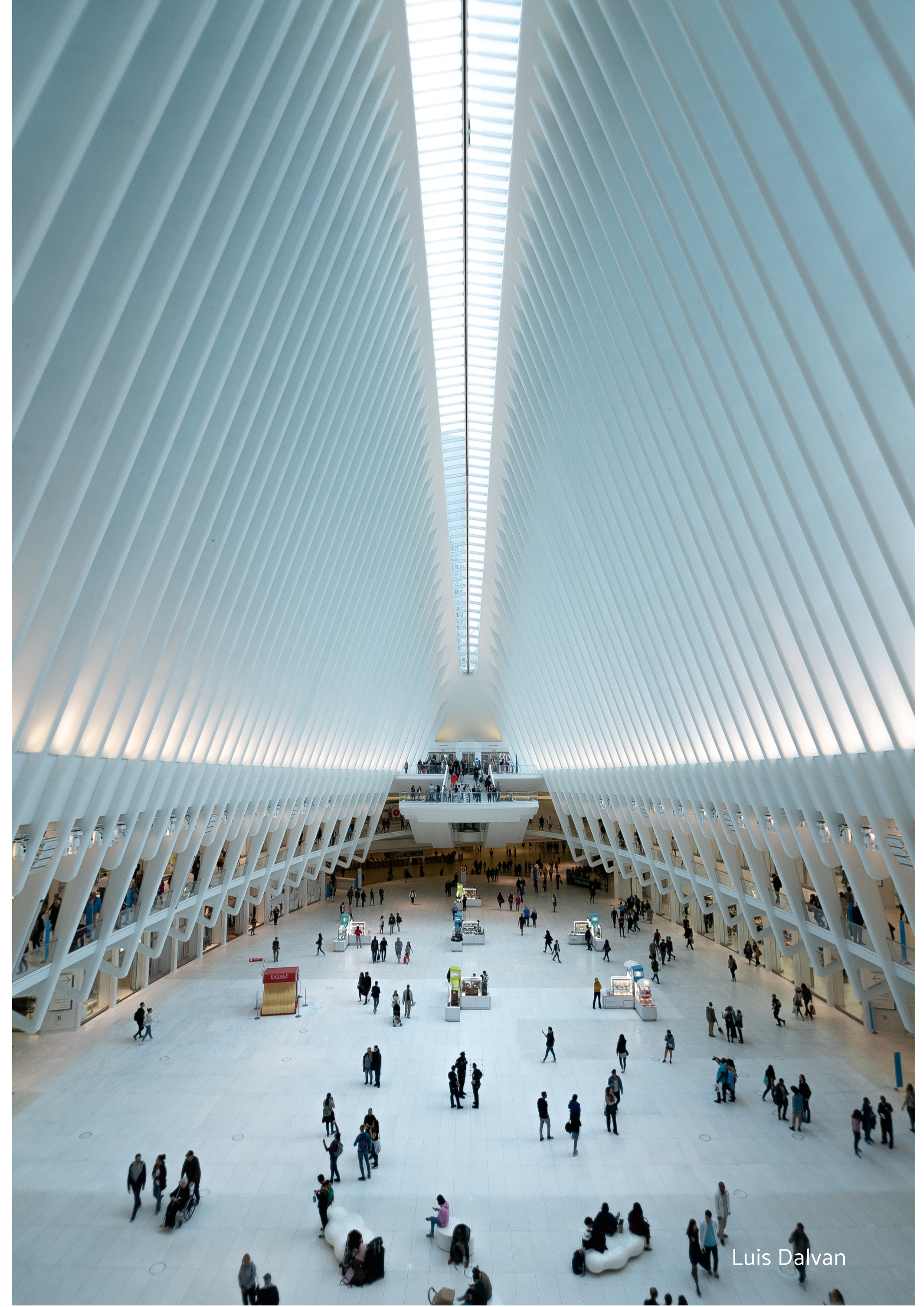

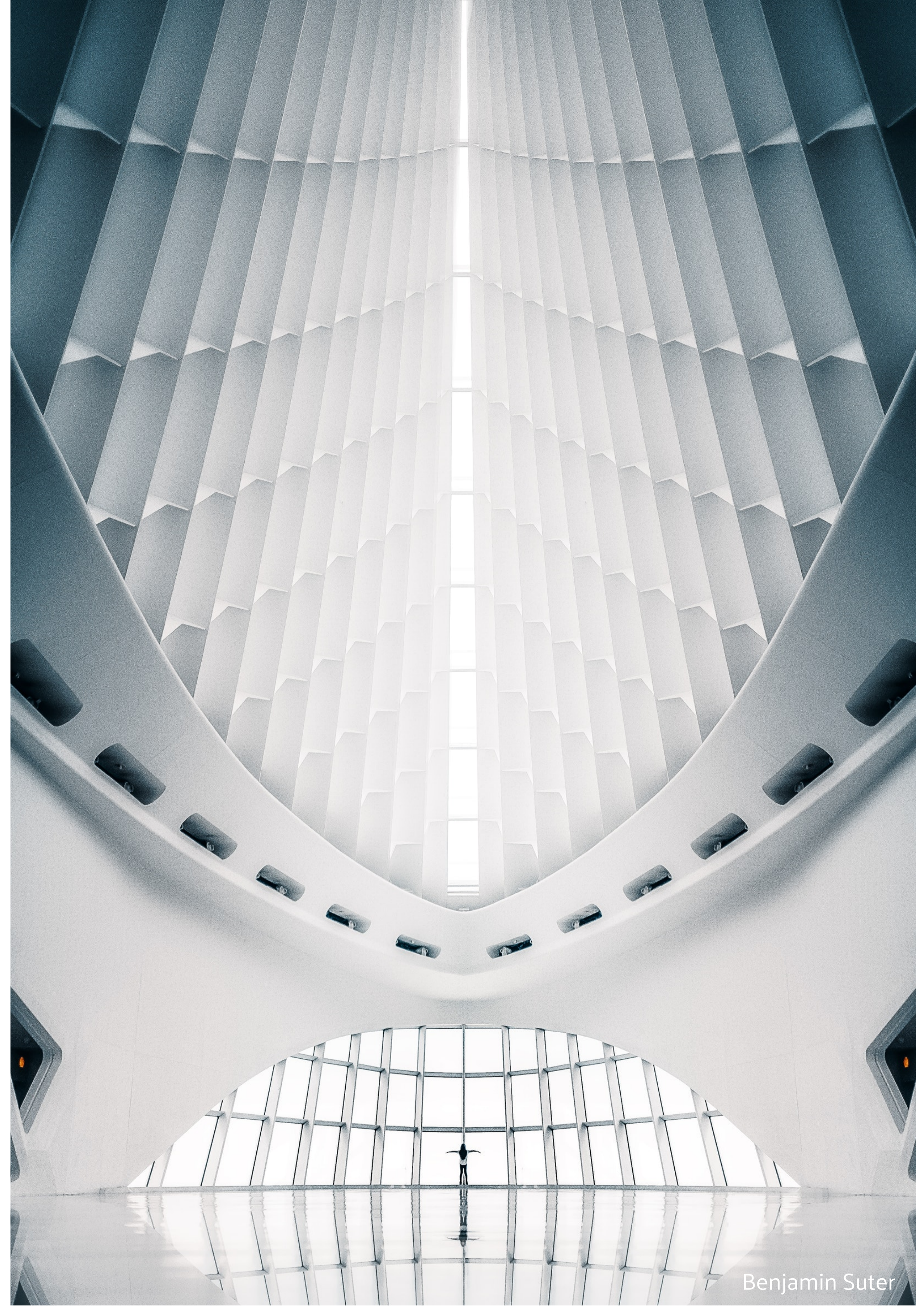

# Biophilic designs in the industry

I was once looked into architecture as my older brother wanted to major in the industry. So being the curious person I was I tried to learn everything I could about the topic. One topic that really stayed with me and helped me sway my decision to move into the design industry was **biophilia**. Biophilia is a Greek word that means love (Philia) for life (Bio). Biophilia is a type of architecture that connects man made buildings and structures with the natural surrounding environment.

The world is developing at a rapid rate and as life becomes urbanized the connection to nature has deteriorated. And this category of architecture tries to rebuild that connection by utilizing natural light, green spaces, and organic materials.



## Solar trees marketplace

Architect Koichi Takada uses biophilic designs to connect the structures with the natural environment. He has a series of architectural biophilic “trees” that can be found in the Solar Tree Market place. It was created as an extension of the indoor outdoor area and is sustainable due to the solar power and energy being generated but also is extremely cohesive with the tall trees found in the area. It allows sunlight to grow and feed the trees but also cools the customers whilst walking under the shaded biophilic trees.









# VINES BY | ARCHICOUTURE

Badria Hamed Kazim

Fashion & Art



## Inspiration

Vines was inspired whilst Badria Kazim was in Rickmansworth, England. "Sitting in nature is inspiring, as an artist connecting with the world we live in helps a creative connection spark unlike no other."

The wrapping of the fabric around the waist causes a synch and therefore allows true skin color to seep through providing the same concept as Badria Kazim's other designs.



# PSYCHOLOGY

Color. Something that is emphasized on when studying design. Because color is such a critical component of the world and has created a deep connection with emotions in humans it is important to utilize that tool to benefit design and art. The colors in the environment are perceived by the brain and the brain then subjectively judges and evaluates what it recognizes.

The first investigation of the effect of color on humans was conducted by Faber Birren in the 1960's. Frank and Rudolf Manke, who were contemporary students at the time participated in this investigation. By recording raw emotion and bodily reactions to seeing different colors Faber Birren was able to manipulate the contestants by showing them particular colors.

# OF COLORS

By distinguishing the connection with the human mind and color artists all over the world not only used color in an aesthetic manner but also to help convey the mood and message that was portrayed in artworks which changed the way the view interacted with the artist.

# Dominate



Fashion

Artwork





Archicouture | Badria .K.

# Showcase

Here is one of archicouture best fashion designs which Badria Kazim spent a total of 7 hours working, editing, and engineering this piece.



*Badria Kazim*



*Brayden Law*

---

# The Element of line in architecture

**L**ine produces forms and distinguishes between architectural types such as modern and classical.

Line is one of the most essential aspects of art, as taught in visual arts. It has the ability to adapt and alter the message being transmitted, but it also has the ability to beautify that message. Art and architecture styles coexist and are extremely similar, with the contemporary style employing minimum lines and 2-4 tones of color, whilst classical art and building designs employ more curves and decorations as opposed to a simple design. When it comes to working drawings, lines are the most expressive component. Every line utilized in the design must have a certain meaning or else it would be meaningless.

Lines are used to divide space, guide the user's attention, generate flow, provide focus, and arrange all design components into shape.

Vertical lines may give a sense of grandeur or spirituality by simulating height. Vertical line usage in churches and cathedrals, where ceilings are elevated on towering vertical pillars leading the gaze upward, is a great illustration of this. Vertical lines in web design are used to symbolize or generate length and to communicate to the user that there is more material below the fold.

Horizontal lines, on the other hand, tend to be quiet and discreet, but vertical lines are more imposing and forceful. Horizontal lines are well renowned in web design for their capacity to arrange material. When looking at gridded layouts, you will note that horizontal lines are the components that provide balance and order, despite the fact that grids are typically set vertically.

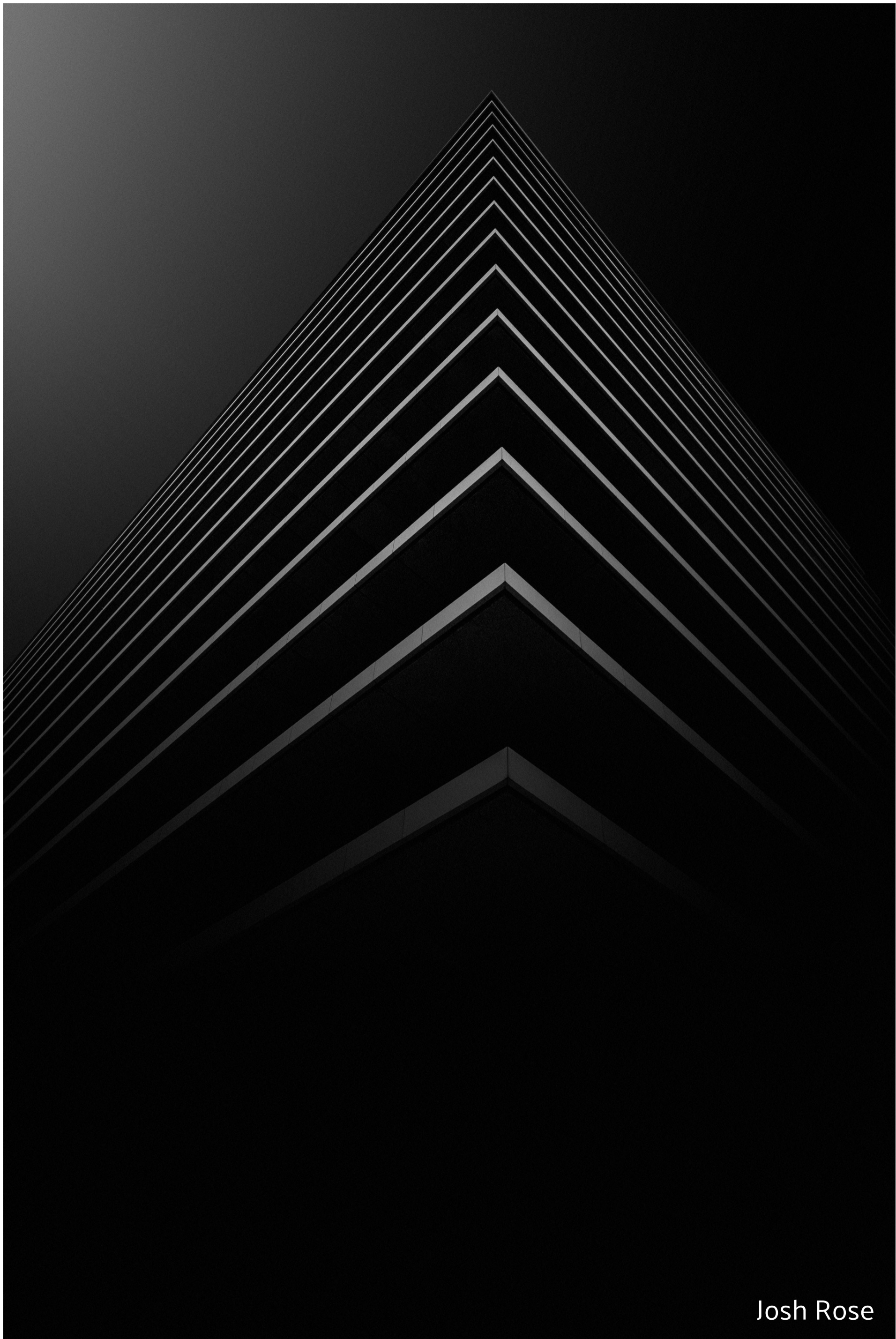

Josh Rose





# Anomaly Fashion

as seen on website



## Abdullah Al Muhaisen

As a half Jordanian half Pakistani boy who has lived in Dubai my whole life, I feel like my roots are embedded in many cultures. I have been embraced by all members of the community as a third cultured child but have lacked the connection with either culture and so I was inspired to create Anomaly. Our hope is to keep people connected to their heritage even if they're away from "home". I have always been passionate about designing and creating my own fashion line so I thought why not incorporate something that would resonate with people all over the world! - Abdullah



## Nishika Kulrani

Being someone who didn't grow up in India, I always felt a little out of my depth when speaking on something that is 'Indian'. Even though I grew up in an Indian community and celebrated all our customs and was informed on most things going on in the country, I always felt like I was a fusion of my environment as well. This visual represents the pride I feel when I think about the opportunities I have because I come from a position of exposure and openness to other cultures - Nishika

## About the company

### As seen on the Anomaly Website

An Anomaly is something that deviates from what is normal or expected. In Fashion, Anomaly is a means of self-expression through luxury street wear; in a way that has never been done before.

As third cultured adults from backgrounds such as the UAE, India and Jordan we have a deep understanding for what it means to be an amalgamation of culture, traditions and values. We believe that fashion is more than just clothing, it is an expression of self. We aim to embody these values through our clothes and take you through a journey that you love as well.

At Anomaly, we work to incorporate symbols across our Indo-Arab cultures while embodying contemporary fashion. It is a constant reminder that no matter where we are, we are always connected to our heritage and will find our Eastern motifs sprawled across our Western constants.

Working and experimenting with fabrics, trends, patterns and colors that come from the East by amalgamating it into our clothing is an ode to appreciating the layers and complexities that organically exist within our society.

Regardless of whether you identify as Indo or Arab, we have a place for you and we believe that our clientele across the globe have the right to be Unfiltered, Unapologetic and Unconventional.



# Influence on Fashion

Social media has swiftly revolutionized nearly every sector in the globe in the last decade, and fashion and fashion journalism are no exceptions. Even the world's top news organizations have had to change the way their readers consume information, putting social media platforms at the forefront of their news delivery. Social media has brought connectivity, creativity, and diversity to the fashion business. Instagram, for example, operates as a live magazine, constantly updating itself with the greatest, most current trends while allowing users to engage in fashion rather than simply watching from afar.

Before social media, being a fashion icon was nearly impossible. Someone in the fashion business had to have seen you and thought you were amazing. They had to create your brand from the ground up. Unless you were famous through other means, your road would require audition after audition, deal after deal, catwalk after catwalk, and you would still have only a remote possibility of becoming a known fashion icon. However, social media has altered the game.

Instead of waiting for someone to find them, users are discovering themselves. Users are creating their own brands and discovering their own friends and following using new technologies like Instagram. Instagram has provided ordinary individuals with access to possibilities that they would not have had otherwise. Rihanna recruited a person to feature in her music video in 2015 by sending her a direct message and stating she loved her style. To advertise their items, New York retail agencies and companies may simply discover self-made Instagram models who fit their brand and have huge followings. Social media has enabled users to form their own online fashion communities, which eventually results in community leaders, and some of those groups are so huge and diverse that their leaders have become identifiable fashion industry celebrities.





Sarah Dorweiler



Denise Duplinski

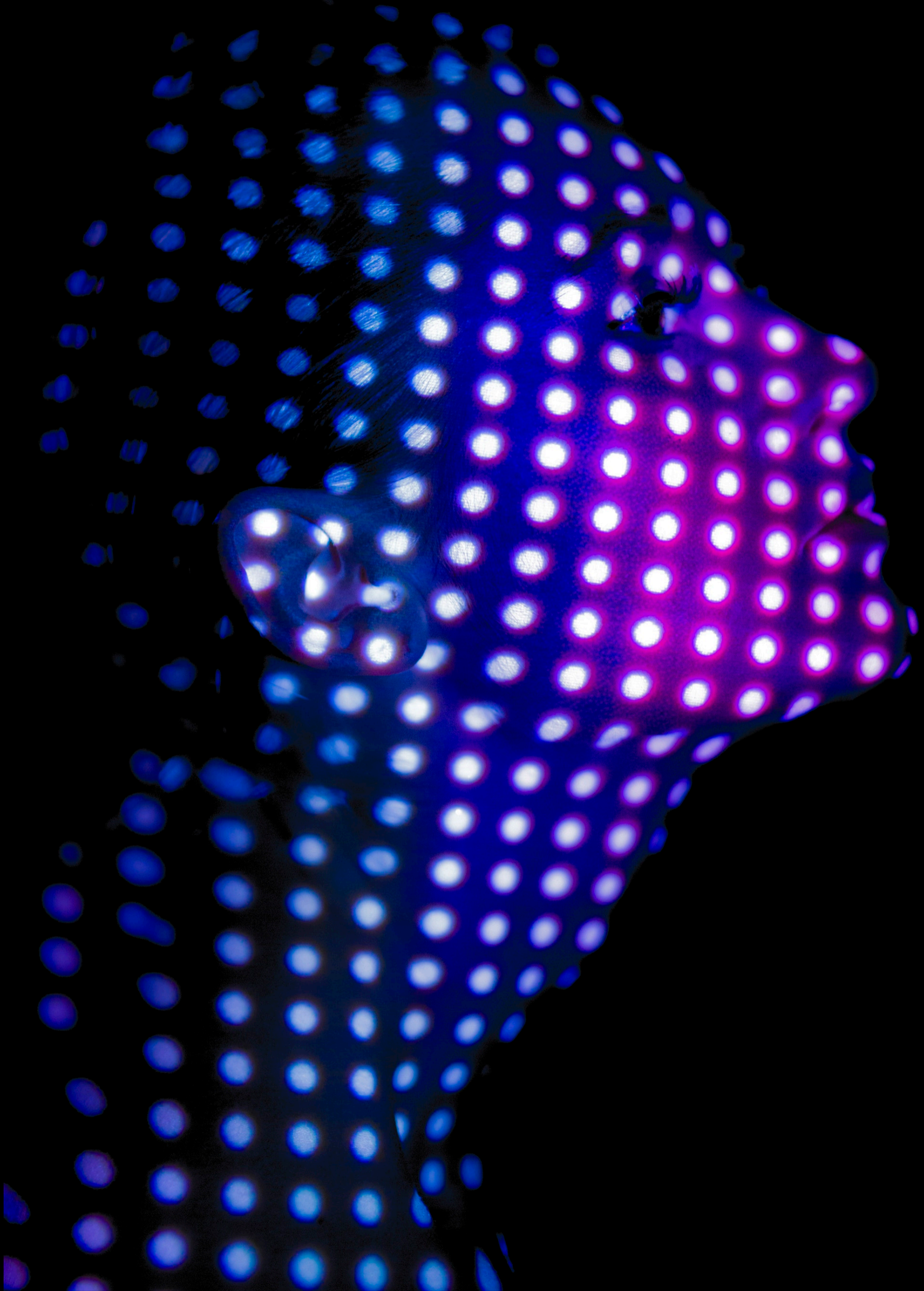

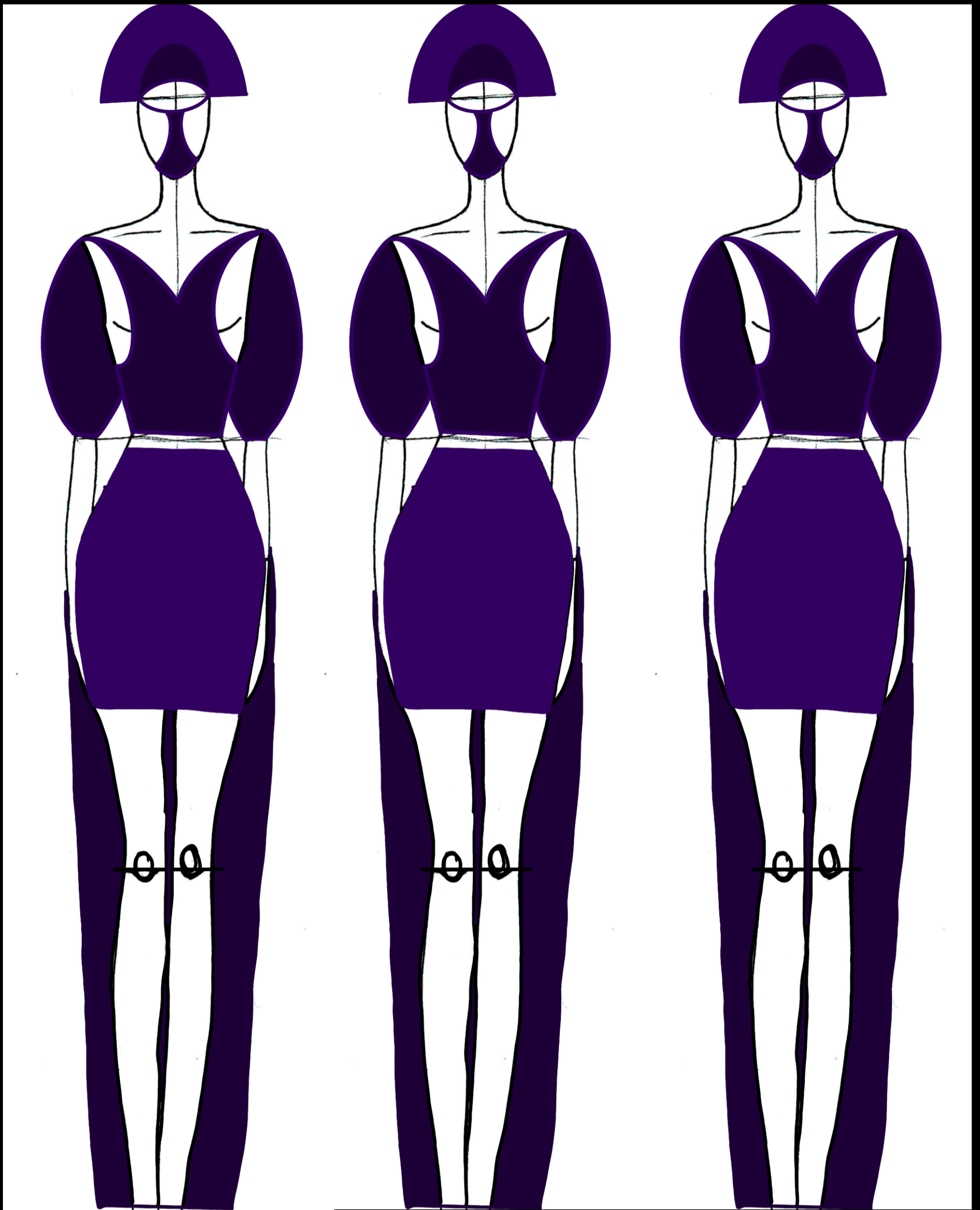

## **Purple**

## **Perfection**

Regality has been revolutionized. This dress designed by Archicoutures Badria Kazim is a complex two-tone design that mixes in many aspects of fashion that have not been introduced in the past. Classical princess sleeves combined with a long flowing sheer backing to a dark skirt. This design is one sure to make it to the red carpet, and grasp the attention of every attendee.

## **Brick Gowanus Neighborhood**

Brick was chosen as one of the main materials after the Great Fire of 1835, and it can be found as a distinctive feature of many of the city's six stories historical buildings. Those are located specially on the smaller east-west streets.

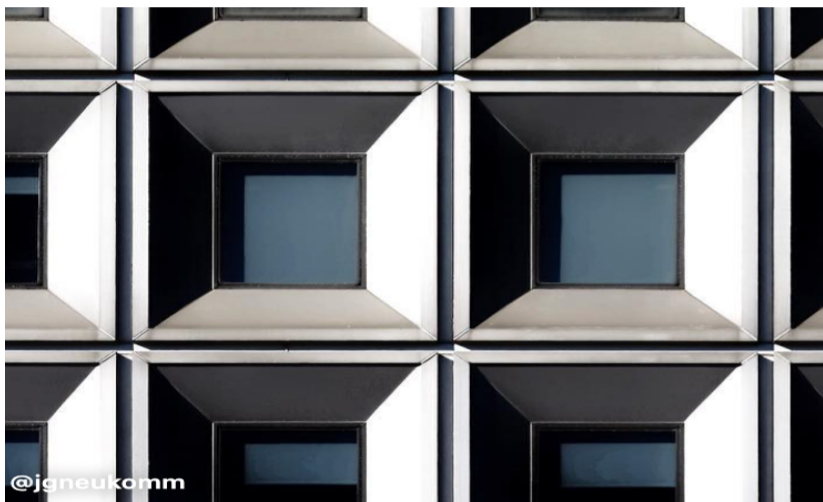

## **NY materials**

Inside the buildings, as numerous studies have shown, natural light has a positive physiological impact on people, stimulating the body's production of hormones and helping regulate the biological clock.

## **Glass + Steel The Artisan**

Outside, glass can have a different effect. Combined with metal, it normally reflects the blue of the sky. This bright, bluish combination is reminiscent of technology, the future, something distant - and for passers-by, it can seem unattainable.

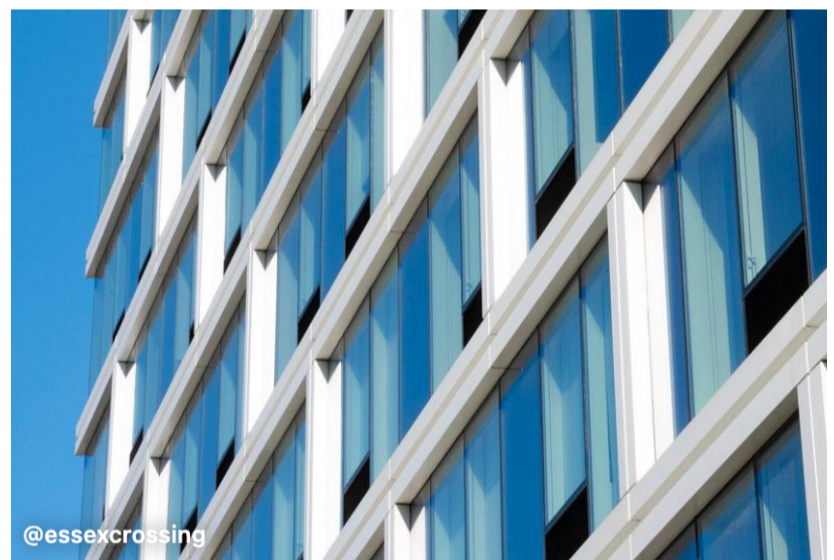

## **Introduction**

Several studies have demonstrated how colors, textures, and materials can directly influence human behavior - it affects people physiologically and psychologically and how they respond to the environment.

The main materials that characterize New York and its respective colors affect the way the city is seen and felt by passers-by.







# Who is Zaha Hadid?

Zaha Hadid was a radical deconstructivist architect recognized for her radical deconstructivist designs. In 2004, she became the first woman to be awarded the Pritzker Architecture Prize. Her works include the Heydar Aliyev Centre Baku in Azerbaijan and the MAXXI museum of modern art and architecture in Rome. Zaha Hadid revolutionized architecture by using shapes and lines in new abstract patterns whilst also utilizing light as the main element of her work.

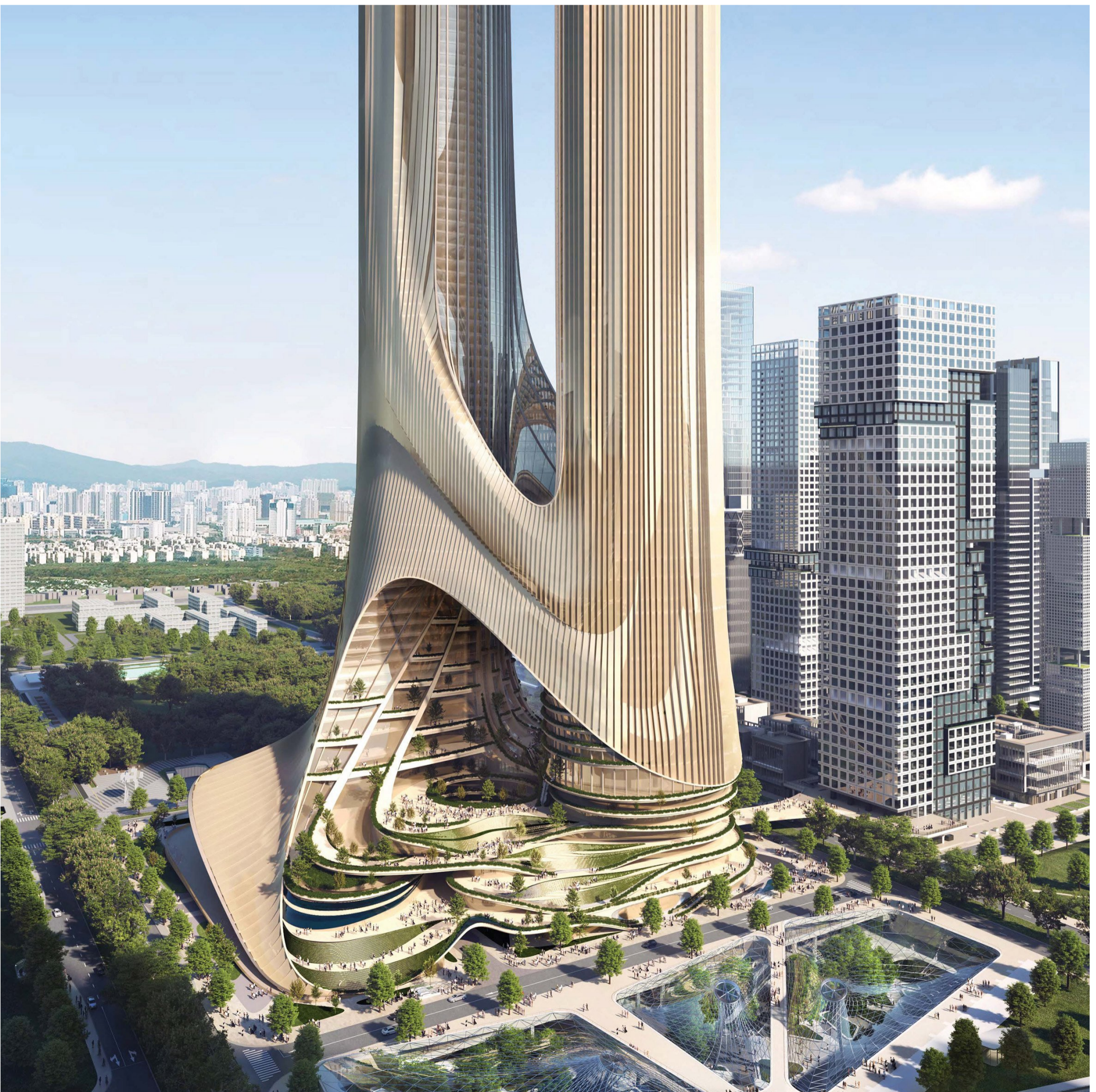



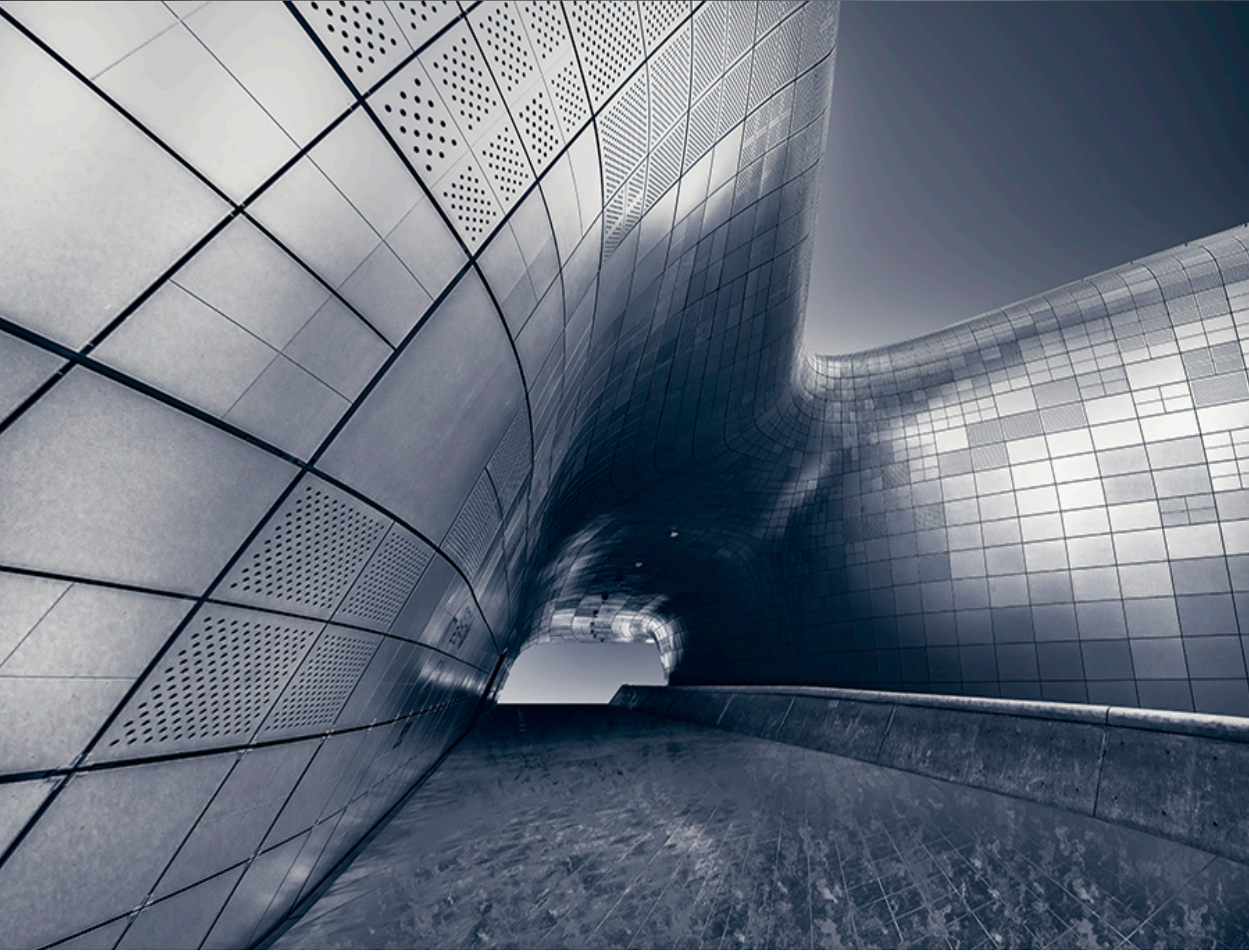

# The Modernity of Zaha Hadid



Hadid studied mathematics at the American University of Beirut before moving, in 1972, to London to study at the Architectural Association School of Architecture. Zenghelis described her as the most outstanding pupil he ever taught. "We called her the inventor of the 89 degrees. Nothing was ever at 90 degrees. She had spectacular vision. All the buildings were exploding into tiny little pieces." He recalled that she was less interested in the details, such as staircases. "The way she drew a staircase you would smash your head against the upper corner of the ceiling. She couldn't care about tiny details. Her mind was on the broader pictures - when it came to the joinery she knew we could fix that later. She was right." She opened her own architectural firm, Zaha Hadid Architects, in London 1980. During the early 1980s, Hadid's style introduced audiences to a new modern architecture style through her extremely detailed and professional sketches. At the time people were focused on postmodernism designs, so her designs were a different approach to architecture that set her apart from other designers. Her reputation in this period rested largely upon her teaching and the imaginative and colorful paintings she made of her proposed buildings.





# Norman Foster and the Apple Park

*Carles Rabada*

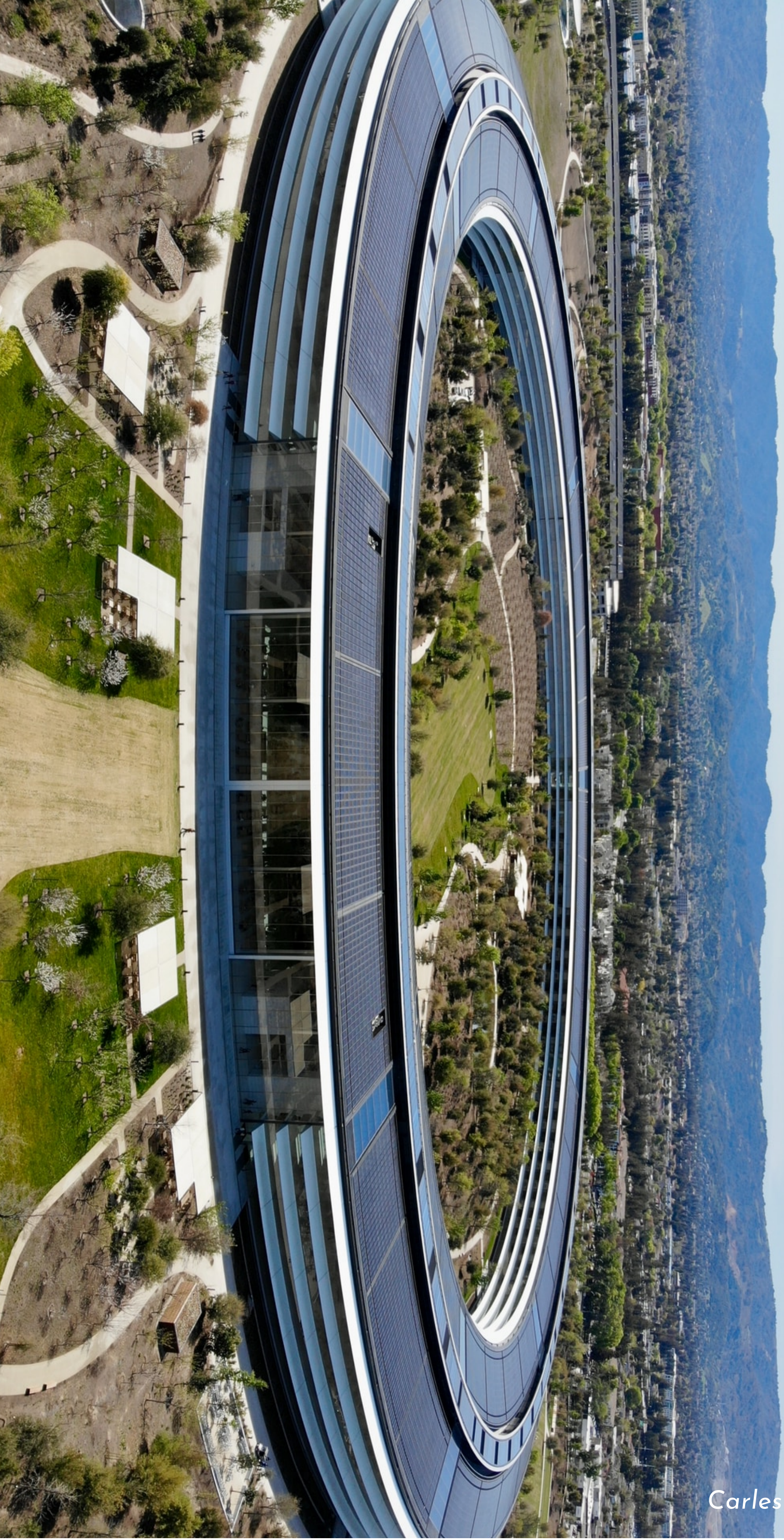

# Norman Foster

## Who Is He?

(According to the Pritzker prize website)

He became the 21st Pritzker Architecture Prize Laureate in 1999. He has been awarded the American Institute of Architects Gold Medal for Architecture (1994), the Royal Gold Medal for Architecture (1983), and the Gold Medal of the French Academy of Architecture (1991). In 1990 he was granted a Knighthood in the Queen's Birthday Honours, and in 1999 was honored with a Life Peerage, becoming The Lord Foster of Thames Bank.

Norman Foster is known as one of the greatest architects in history. He was born in Manchester in 1935 and graduated from Manchester University School of Architecture and City Planning. He proudly received a fellowship to famously known Yale University where he attained a Master's Degree in Architecture. He is the current chairman and founder of Foster and Partners. This architecture firm established a renowned number of projects. Some of which are the New German Parliament which is located in Reichstag in Berlin, and another being the Sainsbury Centre for Visual Arts located in Norwich.

# Apple Park

## How he built it?

Norman Foster and Baron Foster were the key people who worked side by side to develop Apple Park. The Apple Park is a headquarters and campus for apple staff and students. Much like Google Headquarters, the Apple Park features many recreational and working areas for the staff to indulge into. Foster + Partners created this "Park" using no sharp edges, all walls and rooftops are all curved therefore leaving no space in the circle to be completed straight. They also used a significant amount of glass to let natural light flow in and connect the staff to the outdoors.



Matheus Viana



*Joel Filipe*

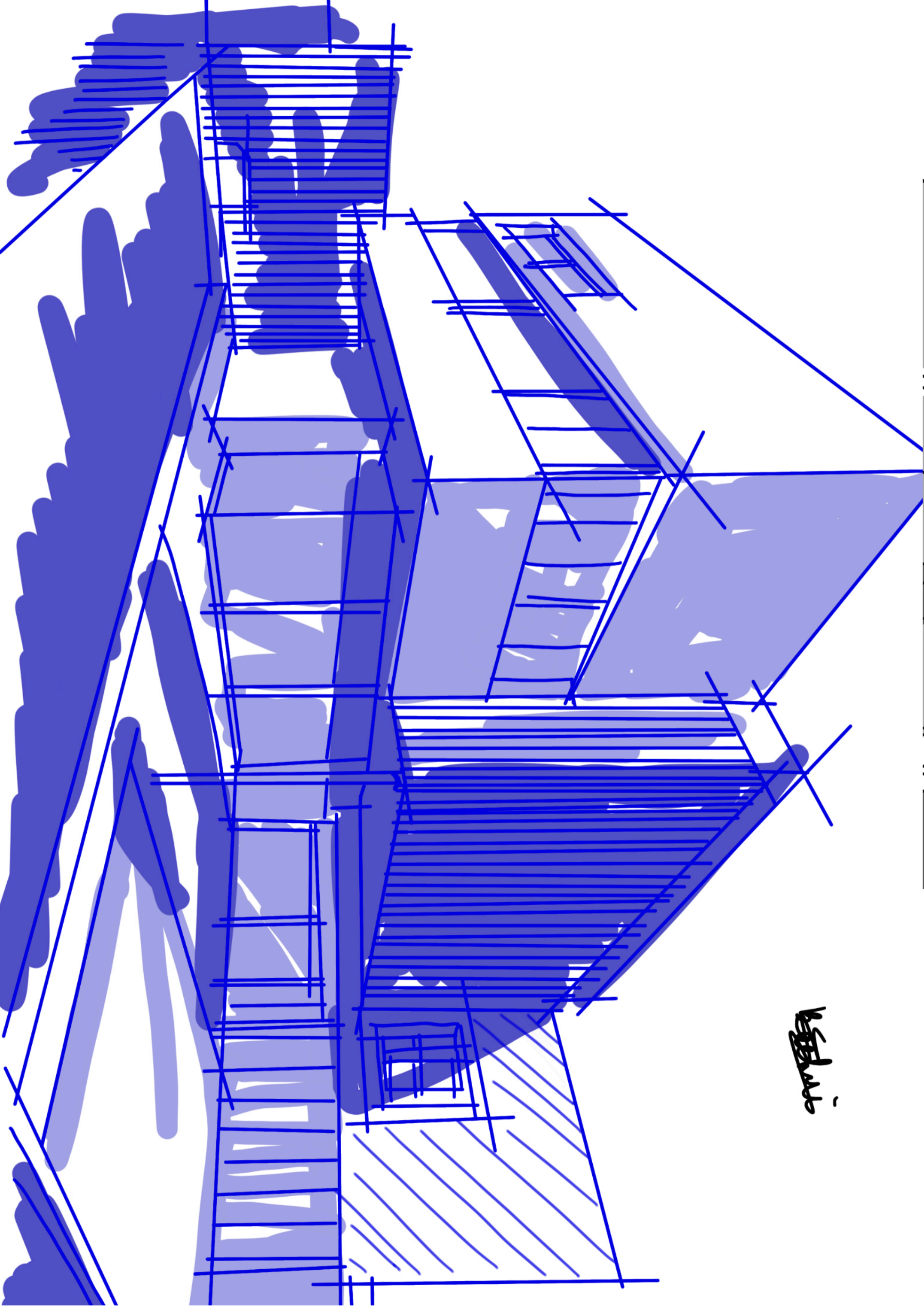

25/11/15

# *Portal To Architecture*

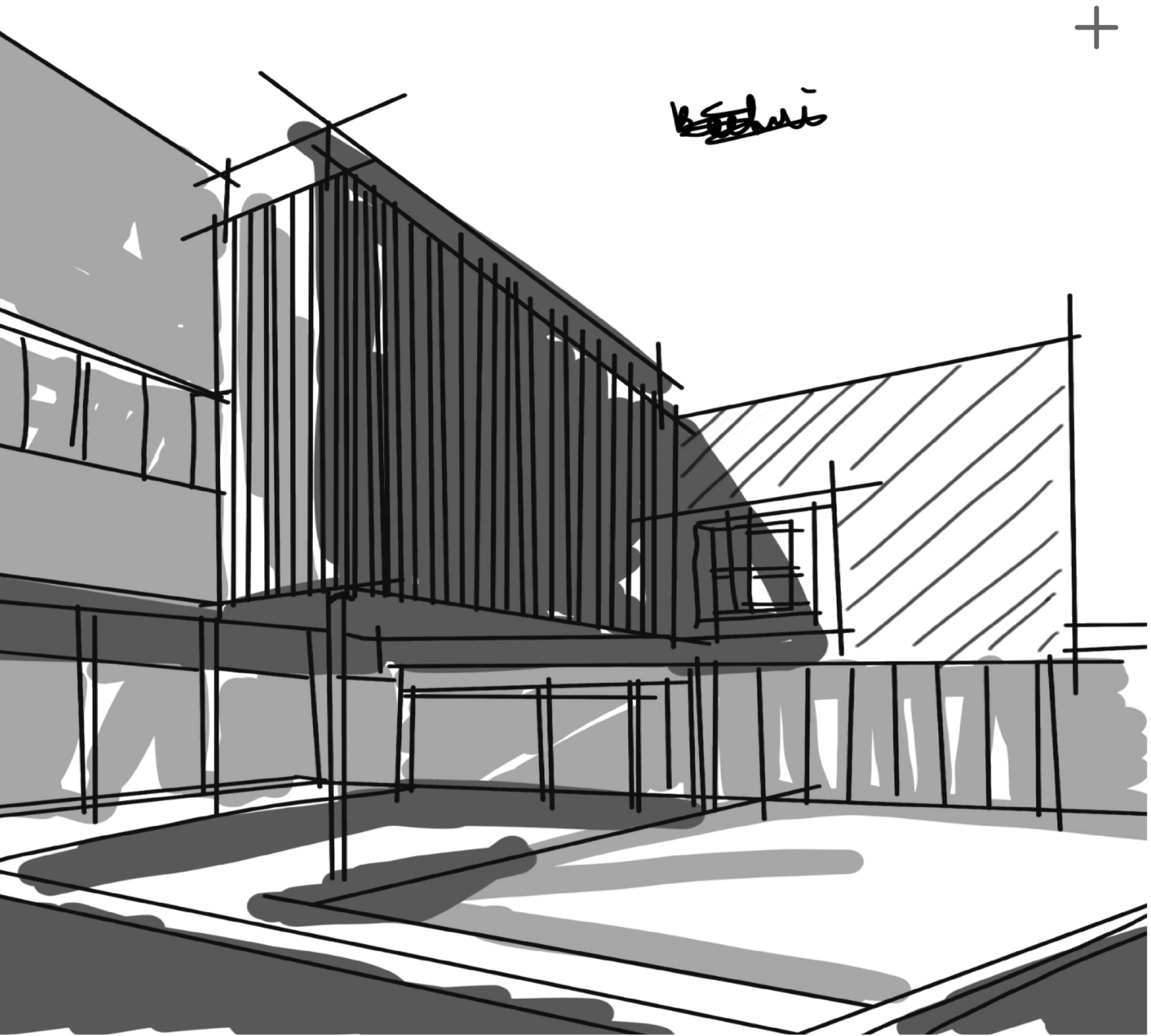

This architectural design was designed by the Editor and Chief of Archicouture herself. " I was sitting with my family discussing the future and our dream houses and rather than sit around and just imagine I wanted to put that vision onto paper." This is just a single of her drafts for a residential home she desires to build.

"I also have been looking into 3D modeling at my current internship at PWC as I am in the emerging technology team. " Using her surroundings and learning as much as possible about technology and how it can collide with architecture.

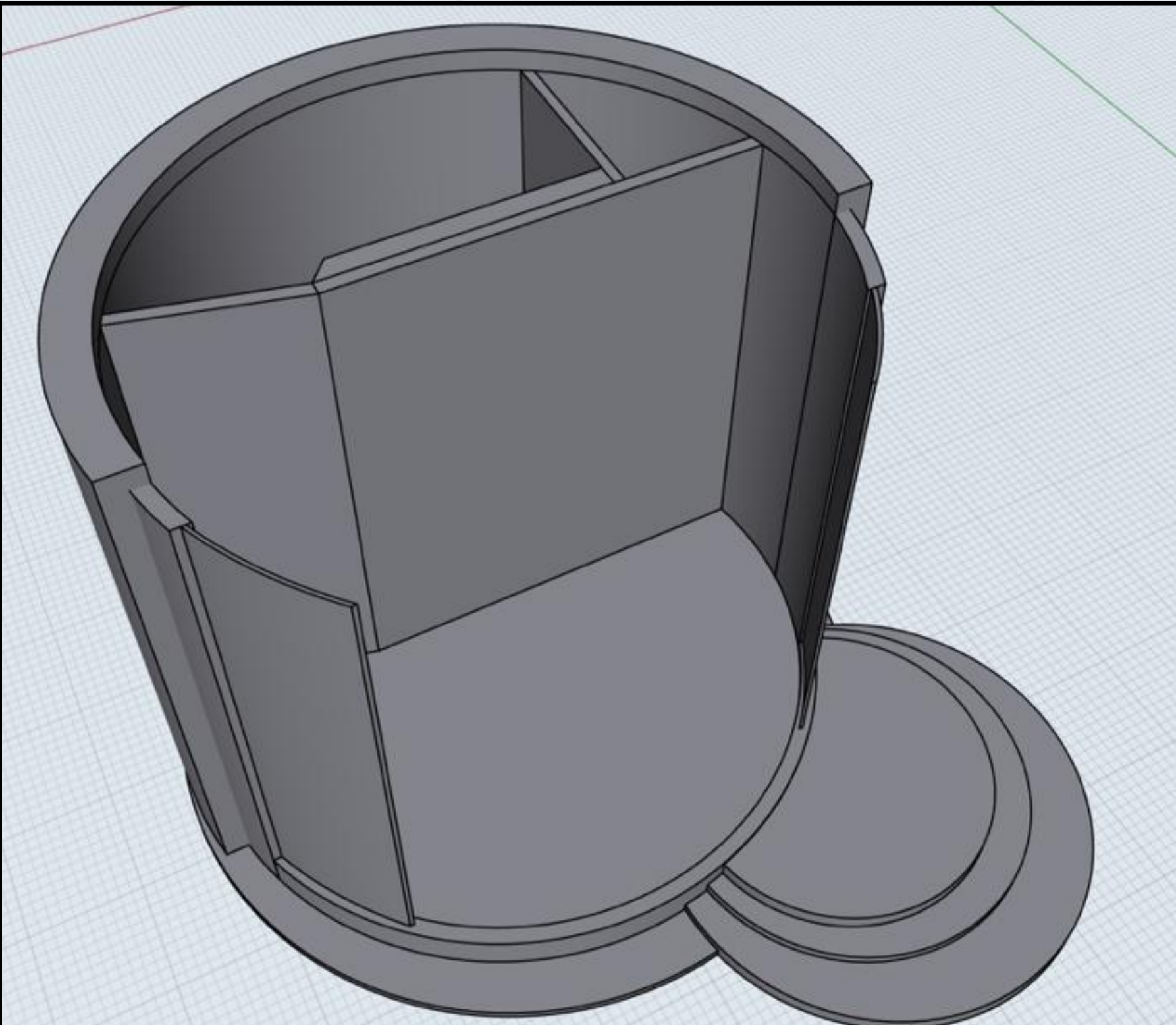
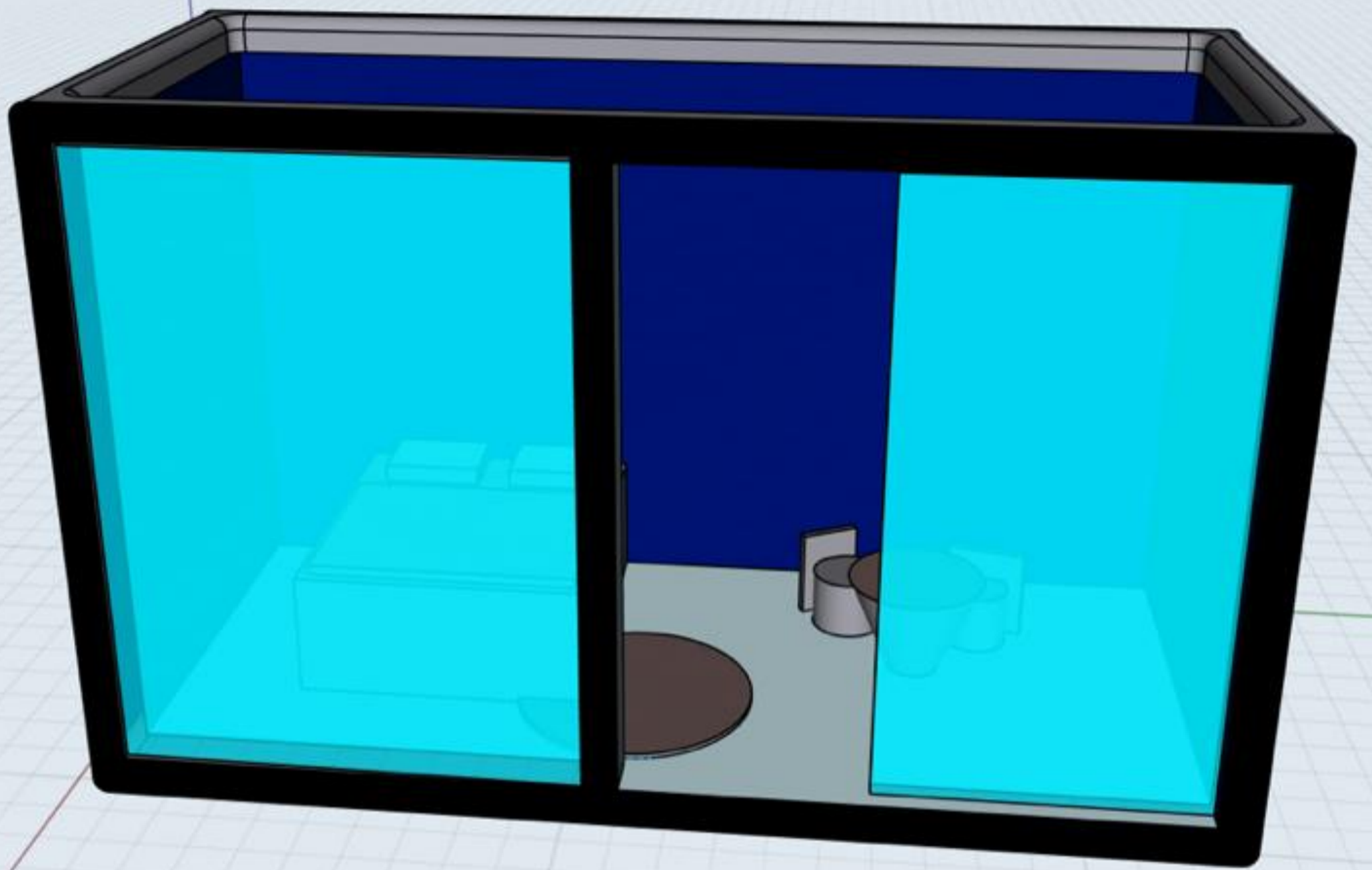

# 3D Modeling

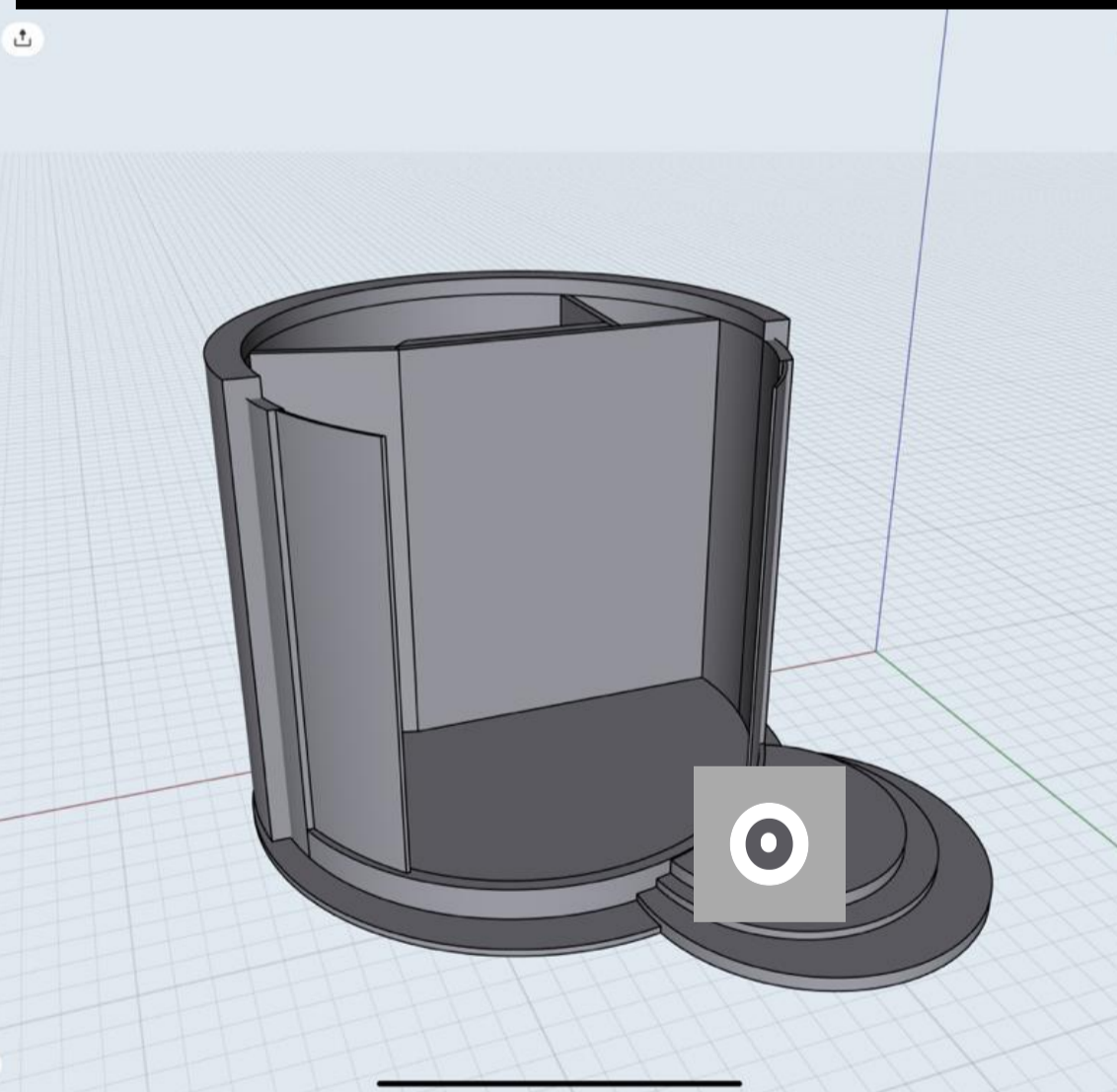
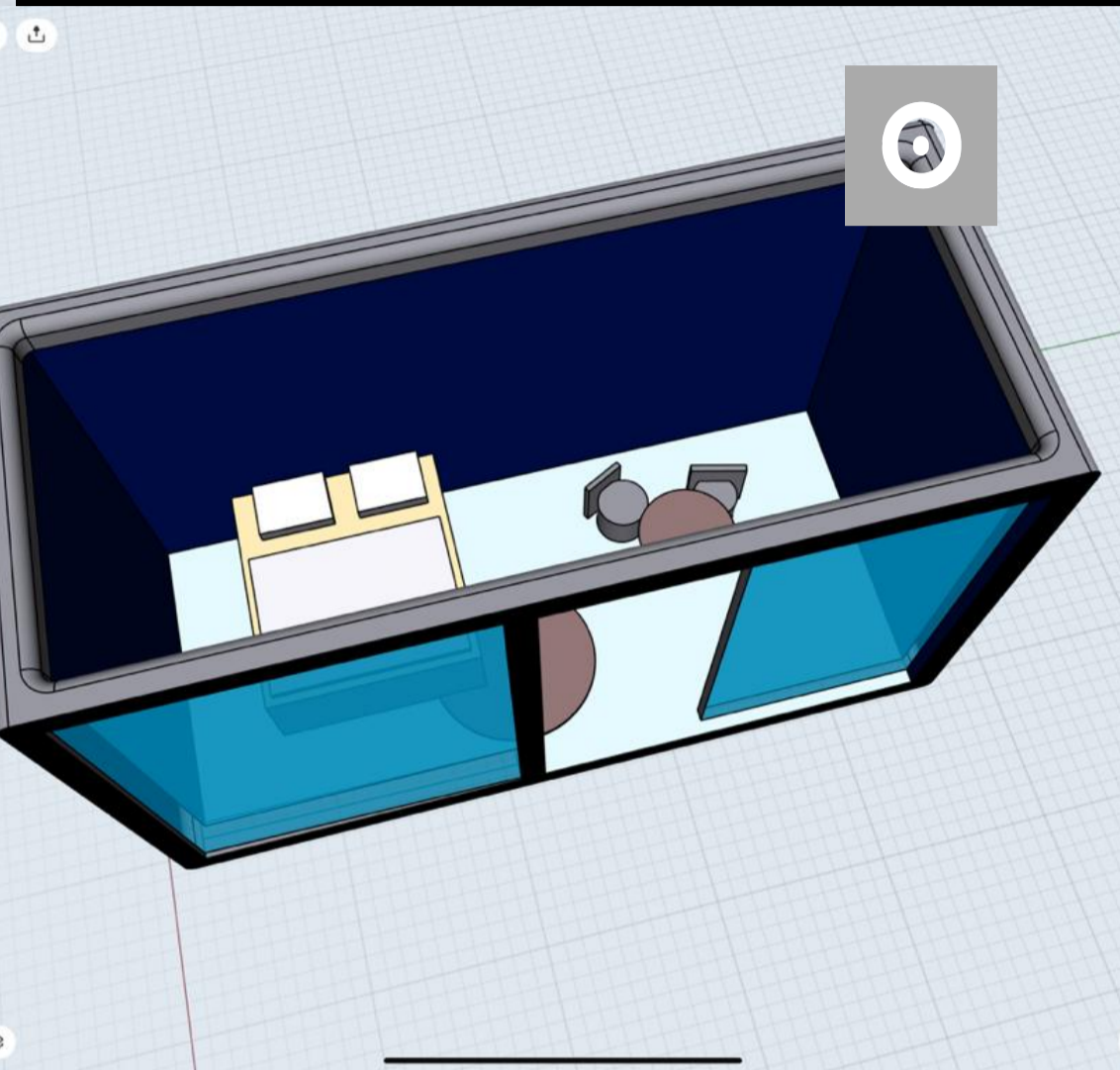

## Design

### 3D Modeled By Badria Kazim

This glamping pod was my first attempt at using a 3D modeling tool to bring my architectural designs to real space. I managed to use the new Ipad Pro's LiDar sensor to apply this 3D model in AR which revolutionized the way architecture would function in my hands from now on.

Rendering and 3D modeling are of utmost importance within the design industries. It helps to sell an idea, speeds up concept approval and identifies any design issues throughout the development process before it takes on a physical form. It can communicate information to clients and customers.



A stack of several leather-bound books in various colors including green, orange, and brown. The top book is a vibrant yellow and features a gold-toned chain detail across its spine. The books are stacked on a wooden surface.

GUCCI

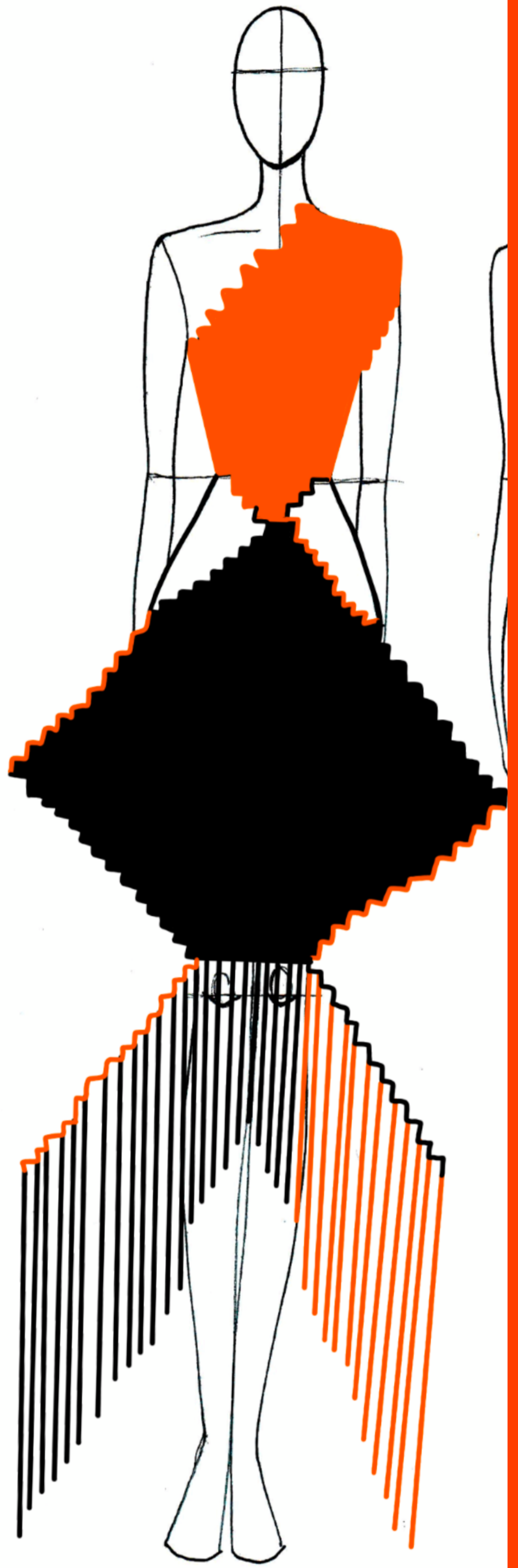
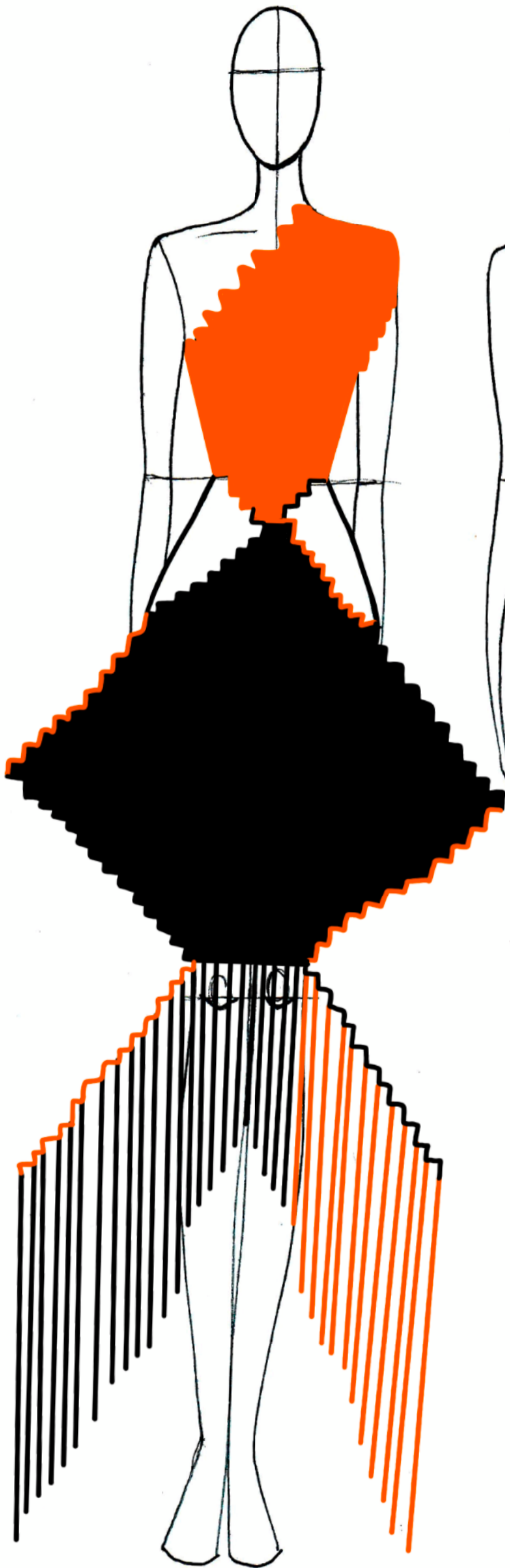

# *Where the Merge begins.*

This design's soul purpose was to see how lines and shapes can be used in an architectural maner but be fitted into a couture dress that would be worn. It upholds the continuity of the two two designs Badria Kazim explores.

*By using orange it attracts the audience to look at the design and then moves the eyes down to the complex staircase which brings the thought of the architecture element being included.*





Badria Kazim





**PRADA**  
MARFA

**PRADA**  
MARFA

**PRADA**

**PRADA**



Benjamin Williams

# *Prada Dynasty*

What was once a chance to exceed in the fashion industry has now taken over the fashion industry. Prada is a Dominion.

**PRADA**  
MILANO

prada milano

Badria Kazim



Yael Clusman

# *iPhone Photography*

Jana Roy is an exceptional photographer, who utilizes an every-day tool to shoot high quality, 4k photos. She contorts the iPhone in such a way the images that are a result of her mastermind turn out to tell a story to the viewer. She takes you on this journey by explaining through simple 7 minute videos.



Shot By Jana Roy  
Photography.





# *A taste of modern heritage*

## *The Chedi Al Bait Sharjah*

The Chedi is a famous chain of hotelcommencedst famous franchises in Switzerland. The Chedi brings a franchise in the UAE to Sharjah. Many people were confused as to why in particular Sharjah would have such a hotel but this question was answered immediately. The hotel was built on a UNESCO heritage site and some of the oldest bastaki homes. All the owners were related thus combining the land and selling it to the Chedi company. The use of modern linear and minimal architecture mixed with the heavy ethnic history of the site is definitely a place to visit.

During this pandemic many stay-cations commenced, one of the best places to reside in is the Chedi, it is in a secluded area and the service is excellent. However one down-side to staying at the Chedi Al Bait is the dining options. One international restaurant is available for breakfast and lunch which is the only dining option within the hotel at the time, another arabic restaurant is available for dinner and is the only dining option at the hotel at that time which is a very limited selection.

Overall it is a site to see and not bad on the pricing side either. The suggested time to stay would roughly be 2-3 nights minimum to gain the whole Chedi Al Bait experience.

Definitely worth a visit.

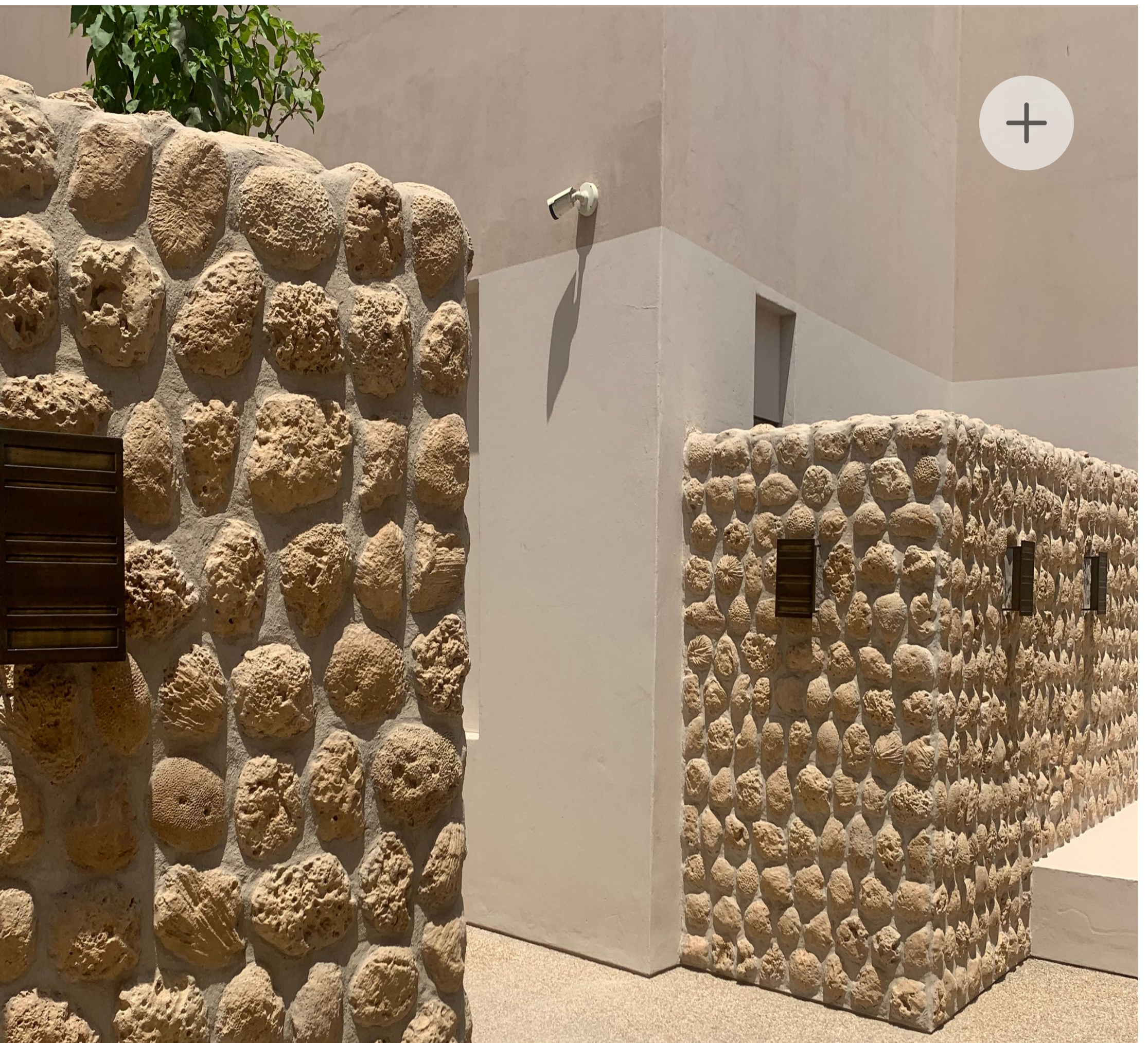

# *Bedouin Era*

Here is an photograph shot by Badria Kazim which showcases the mix between minimalism and ethnic culture at the Chedi Al Bait.







# Alserkal Avenue

A hidden portal to experience  
ART

# About

---

Located in Al Quoz, Alserkal Avenue is a collection of warehouses made into a place of art and expression. The hotspot in Dubai for the newest art pieces and upcoming trends. With a high selection of food and dining areas such as Chai Wala and FOMO burger. Cinema Akil offers old and unique movies being played all the time as well as the yearly Palestinian film festival hosted at Cinema Akil. Crank will get you burning 600-700 calories in 45 minutes, using spinning class mixed with loud music and an endless light show.

Alserkal Avenue is one of Dubai's Hidden Gems, if you are into music, art or anything aesthetic this is the place to hit.

#Support Small Businesses



*An Image taken at Carbon 12 Gallery during the exhibition "The Last Days of Soft Machine" Captured by Badria Kazim*

---

# The Expression of culture in design

**M**odern Design is moving like a ferrari with a bicycle break, constantly moving. Every year new trends are created from new designers.

Certain colors and connotations associated with a culture or religion are expressed in artwork and design. All design has a base or a foundation, and every designer has a base or foundation which they are connected with, this connection is always underlying in the creative process.

Culture is something that many people identify themselves with, there is always going to be a fraction of the world who does not associate with their culture and even they will show that in their design and artworks. This is because when the human body is going through a creative process it retrieves memories to try and mix and match until something new has been created. Neurologically when the mind is retrieving memories certain aspects of the brain are activated, and when the mind is thinking of the future the same aspects of the brain are activated, therefore any experiences through one's lifetime will be reflected in their outlook in the future and their image of the final product of that creativity.

When an artist is brainstorming all elements of the mind are included, logic, creativity, realism, optimism, surrealism and many include core values and beliefs which help one perceive certain design elements in a particular manner.

(Culture is so powerful we do not realize that it influences. Design is the same, both influencing society and changing opinions simultaneously. In this sense art is communication because it allows different cultures and people to converse and communicate with one another. The way in which we visualize all the elements of art, both good, bad and mediocre, is influenced by our understanding of the world we live in.

Overall, by understanding what your culture and ethnicity is you are able to contort your perception when viewing and analysing to see new angles of artworks and seeing how the expression of culture in design influenced the designer.

Written By Badria Kazim



---

# Badria Kazim's Artworks



Warmth in Words

This piece was drawn during a day where nothing seemed to fit into place. Frustrated, I reached for my diary to express my frustration, only to realize that the last page had been filled out weeks before. My eyes landed on the physical version of this sketch, one empty and without color, one I had been meaning to refine. My words, my frustration, my fervor, took refuge in the woman's dress as red silk, two pages worth crammed into her clothing.

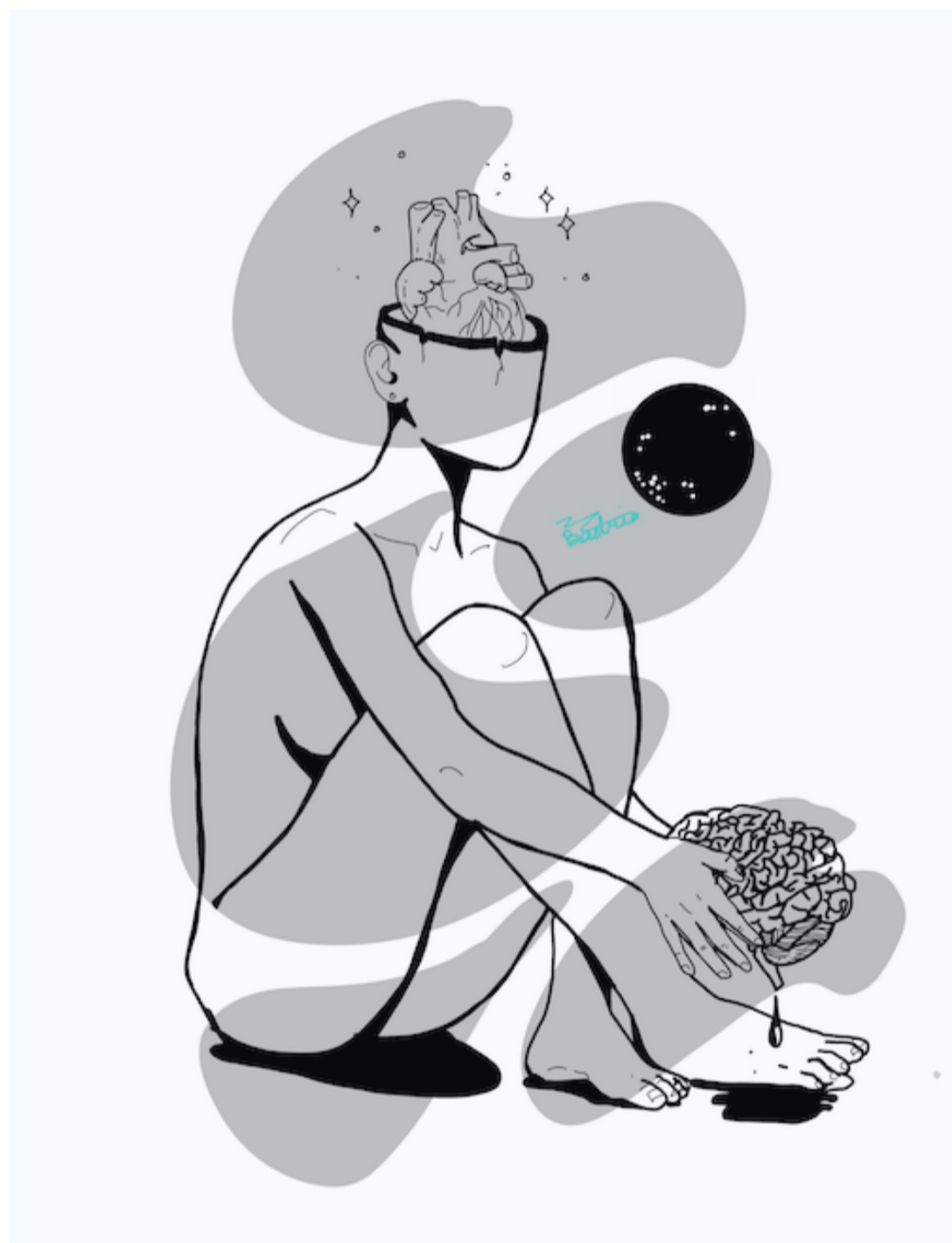

Emotion < Mind

A personal favorite, depicting the clash between the heart and the head. I've always been fascinated by how people declare the fact that they're oriented to one or the other when to me, it was so obvious that there was only harmony between the two, not discord. The heart in the open mind represents the fact that emotion is the true controller of the two, and that if you can control it, you can gradually become a master of your own reality.





Badria Kazim





---

# Costume Design in Dune

Dune is a new and upcoming film that has taken the internet by storm due to the incredible lineup and cast. However, one aspect of the film is noticed, the costume design. The color and geometric configuration of the clothing have been chosen to fit the aesthetic of the brown and dirty tones which are seen throughout the film. The costume designer did a fantastic job of fitting the designs with the storyline and configuring different materials within the costume such as carbon fiber and steel as well as specific padding to create geometric shapes and distinguish the warriors from the royals.

The fitting and shaping of each individual costume also are significant as all of them do not look the same and have been tailored specifically to fit the actors and actresses' bodies and to bring out certain elements of authority for each character.





# WOMEN IN THE UAE

The Uprise of woman



Emirates woman

# WOMEN IN THE UAE

Women in the UAE have been included in many things, unlike the rest of the world, the UAE strives to bring women into men dominated industries. Gender pay gap has also been addressed and diminished. Modern day initiatives and thinking that have been created by the Leaders of the UAE.

According to Khaleej Times, 85% of staff at Sheikh Mohammed's office are women, being a leader of one of the world's modern cities also sets an example of how equality is shown throughout the UAE.

Sheikh Mohammed especially showcases the need for women in men dominated industries as seen on his instagram.

The UAE has rapidly broken boundaries for women. Nour al Matrooshi is the first Arab woman to go to space. According to the Brown Identity, "She, along with Mohammed Al Mulla, will be the UAE's next two astronauts." Another groundbreaking moment for women, especially in the UAE.

# *Credits*

I would like to give a special thanks to all the unsplash photographers whom I have featured their artwork in this magazine. All photography features and credits go to:

***Photography*** /

Credited Photographer	Page
Karl Lagerfeld	4-5
Iris Van Herpen	6-7
Karl Lagerfeld	12-13
Iris Van Herpen	14-15
Luis Dalvan	16
Benjamin Sutler	17
Koichi Takada	18-19
Jeffery Czum	20-21
Pawel Czerwinski	22
Nika Akin	23
Александр Македонский	26
Brayden Law	29
Josh Rose	31
Anomaly Fashion	32-35
Karl Lagerfeld	37
Sarah Dorweiler	38
Denise Duplinski	39
Aleksander Pasaric	40
Architect Hunter Instagram	42
Zaha Hadid Architects	43-49
Louis Vuitton Instagram	50
Carles Rabada	52
Matheus Viana	53
Joel Filipe	54
Hannah Morgan	60
Gucci Instagram	61
Zetong Li	63
Mizzu Cho	66
Benjamin Williams	67
Yael Clusman	69
Nathan Dumlao	71
Vanity Fair	84-84
The Brown Identity & Emirates Women	86-87
Mehrad Vosoughi	88

# *Editors End*

Dear Reader I would like to thank you for your indulgence into Archicoutures first ever magazine. It has been a journey getting to this point and many lessons have been learnt along the way. The combination of color to images has taken days on end to perfect.

I sincerely hope that Archicouture has displayed its true message and the collusion of the two industries is significant throughout the pages of this magazine. In my eyes this is a creative beacon of knowledge to help teach and broadcast the newest and greatest elements of these industries.

## *Editor*

Badria Hamed  
Ahmad Mohammed  
Aquil Kazim

# *Archicouture*



ARCHICOUTURE



# ARCHICOUTURE

*Contact*  
*us*

[theofficialarchicouture@gmail.com](mailto:theofficialarchicouture@gmail.com)